

<b>SIDES</b>	<b>BOTTOM</b>
6 1/2" KNOCKOUTS	3 1/2" KNOCKOUTS
3 1/2"-3/4" MOON KNOCKOUTS	2 1/2"-3/4" MOON KNOCKOUTS
2 PCS 8-32X1/2 Screws Installed	
Material:Steel-0.0625"-G60 Galvanized	

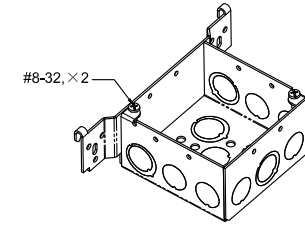

2 1/2"-3/4" MOON KNOCKOUTS  $\phi=22.5 [\phi=0.89]$   
 $\phi=28.5 [\phi=1.12]$  MIRROR

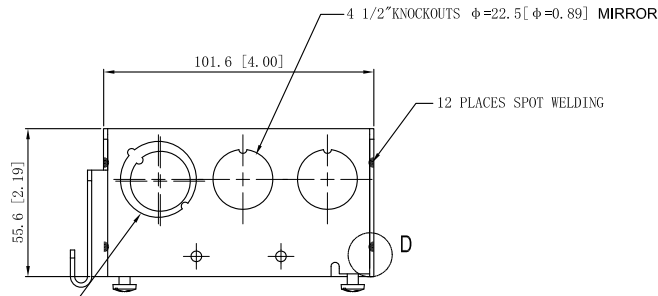
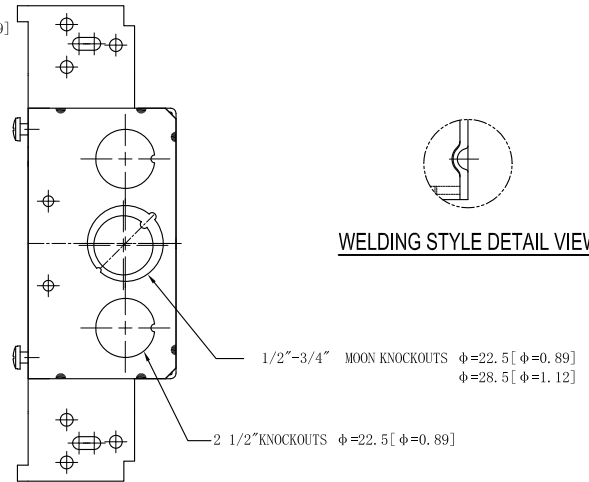
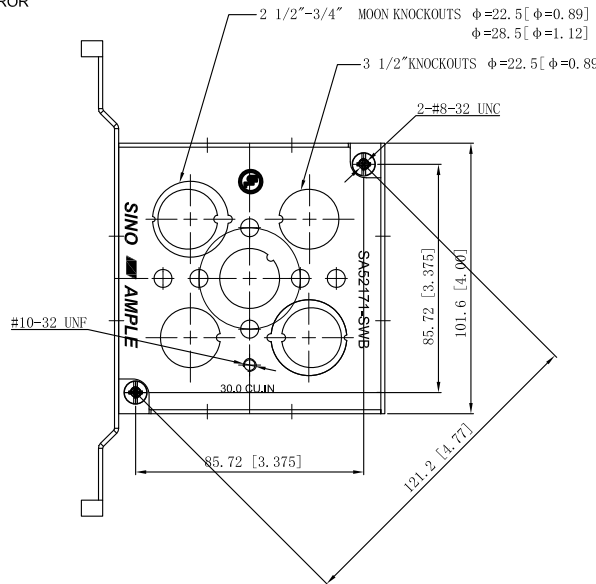
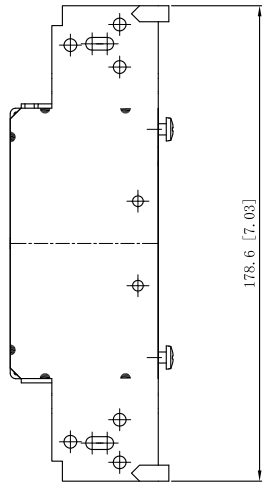

This data sheet is for reference only .SINO AMPLE reserves the right to make changes to the design without prior notice.

DESCRIPTION
TRADE REFERENCE TERMS

STANDARD PACKING	ZHUJI SINO AMPLE METAL PRODUCTS CO., LTD.		
	TITLE	4" SQUARE BRACKET BOXES (2-1/8" DEEP)	
25 PCS	SIZE	DWG NO.	REV
	SA52171-SWB		A
DATA SHEET			