

SIDES	BOTTOM
4 1/2" KNOCKOUTS	3 1/2" KNOCKOUTS
4 1/2"-3/4" KNOCKOUTS	2 3/4" KNOCKOUTS
4 1" KNOCKOUTS	
2 PCS 8-32×1/2 Screws Installed	
Material:Steel-0.0625"-G60 Galvanized	

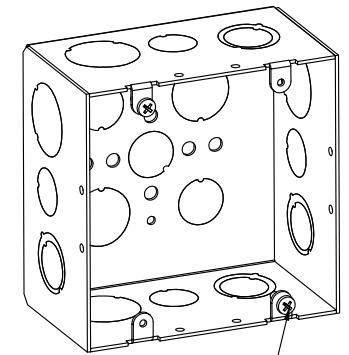

#8-32, × 2

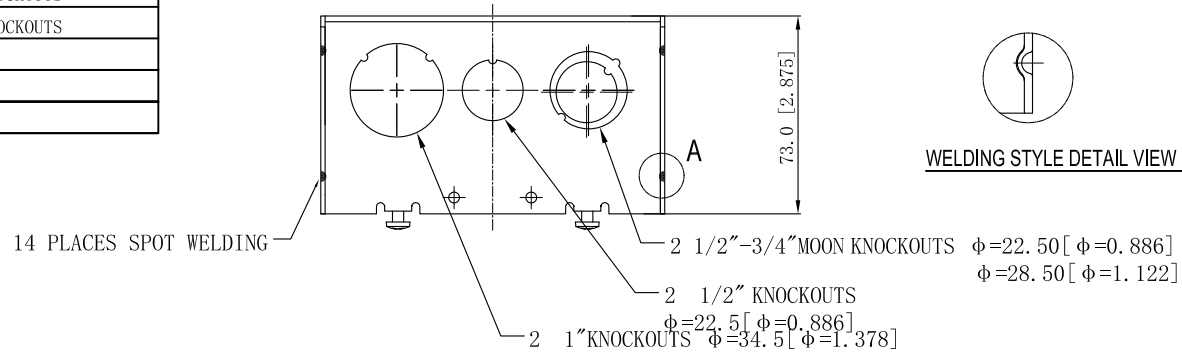
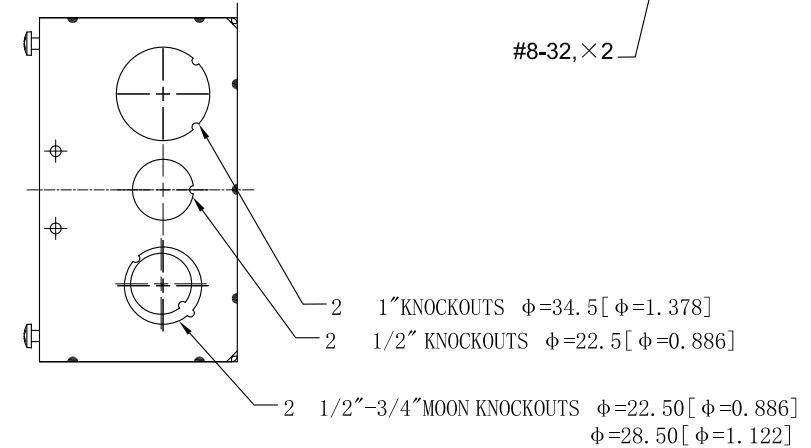
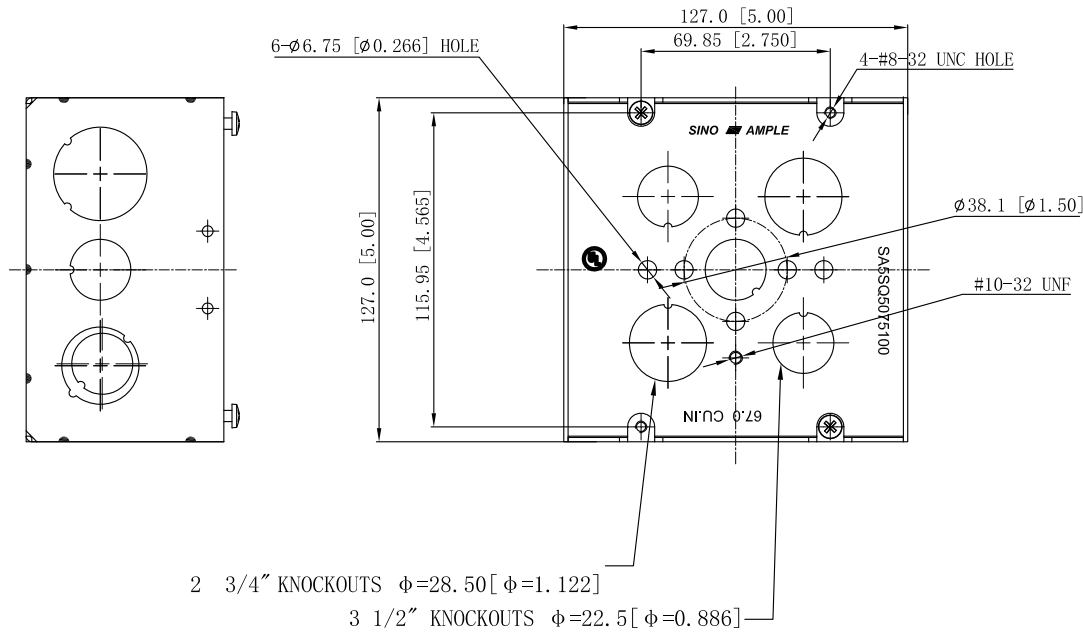

This data sheet is for reference only.SINO AMPLE reserves the right to make changes to the design without prior notice.

DESCRIPTION
TRADE REFERENCE TERMS

STANDARD PACKING	ZHUJI SINO AMPLE METAL PRODUCTS CO., LTD.		
	TITLE 5 in. Square×2.875" Deep Metal Box		
SIZE A4	DWG NO. SA5SQ5075100		REV A
	DATA SHEET		